

NCV8871LVB

NCV8871 Automotive Grade Boost Controller Low Power Boost Evaluation Board User's Manual



ON Semiconductor®

<http://onsemi.com>

EVAL BOARD USER'S MANUAL

Description

The NCV8871LVB evaluation board provides an opportunity to evaluate the NCV887100 in a 10 W start stop boost application. The board supplies a 10.6 V output with 1 A of output current from as low as a 5 V input. The enable pin can also be used to synchronize the supply to an external clock.

Key Features

- 10.6 V Output Voltage
- 1 A Output Current
- Fixed Frequency Operation at 170 kHz
- Regulates Fully Loaded From as Low as 5 V Input
- Survives 35 V Load Dump
- External Clock Synchronization up to 340 kHz
- Automotive Grade



Figure 1. NCV8871LVB Evaluation Board

NCV8871LVB

Table 1. EVALUATION BOARD TERMINAL DESCRIPTIONS

Terminal	Function
VIN	Positive dc input voltage.
GND	Common dc return.
VOOUT	Dc output voltage.
EN/SYNC	Dc enable voltage and external clock synchronization. A dc logic low disables the device.

Table 2. ABSOLUTE MAXIMUM RATINGS (Voltages are with respect to GND)

Rating	Value	Unit
Dc Supply Voltage (VIN)	-0.3 to 35	V
Dc Supply Voltage (EN/SYNC)	-0.3 to 6	V
Ambient Temperature	-40 to 85	°C

Stresses exceeding those listed in the Maximum Ratings table may damage the device. If any of these limits are exceeded, device functionality should not be assumed, damage may occur and reliability may be affected.

Table 3. ELECTRICAL CHARACTERISTICS (TA = 25°C, 4.5 ≤ VIN ≤ 18 V, IOOUT ≤ 2 A, unless otherwise specified)

Characteristic	Conditions	Typical Value	Unit
Output Voltage		10.6	V
Voltage Accuracy	-40 ≤ TA ≤ 85	4	%
Switching Frequency		170	kHz

Product parametric performance is indicated in the Electrical Characteristics for the listed test conditions, unless otherwise noted. Product performance may not be indicated by the Electrical Characteristics if operated under different conditions.

NCV8871LVB

SCHEMATIC

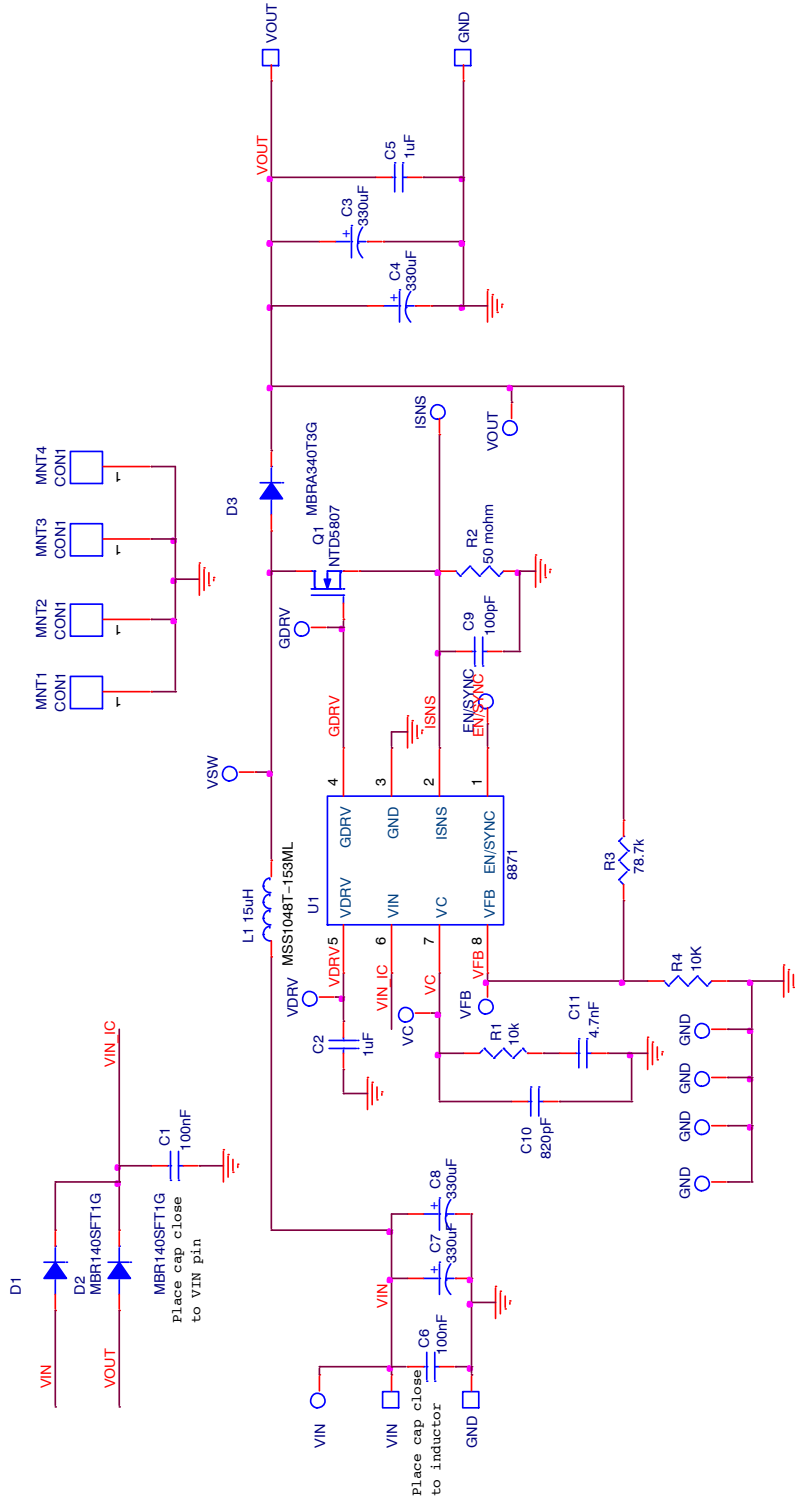

Figure 2. NCV8871 Evaluation Board Schematic

NCV8871LVB

PCB LAYOUT

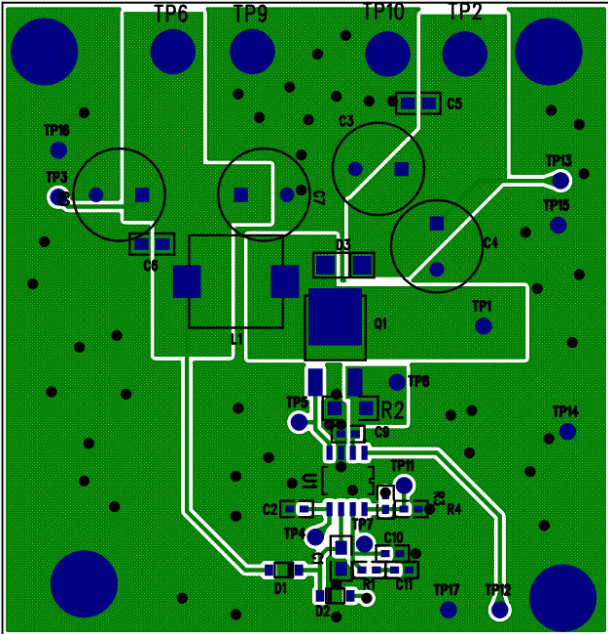

Figure 3. Top Layout

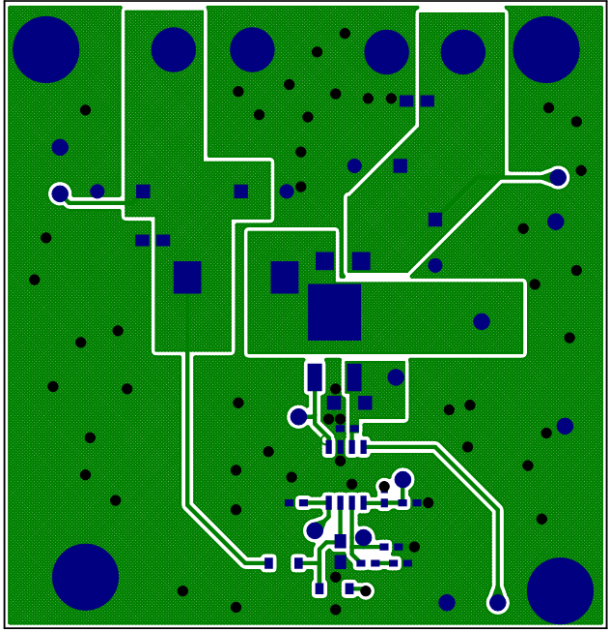

Figure 4. Bottom Layout

NCV8871LVB

BILL OF MATERIALS

Table 4. BILL OF MATERIALS

Item Number	Quantity	Value	Part Number	Part Reference
1	2	100 nF	GCM188R71H104KA57D	C1, C6
2	1	1 μ F	GCM188R71C105KA64D	C2
3	4	330 μ F	35ZLH330M10X12.5	C3, C4, C7, C8
4	1	1 μ F	GCM21BR7YA105KA55L	C5
5	1	100 pF		C9
6	1	820 pF		C10
7	1	1.5 nF		C11
8	2	MBR140SFT1G	MBR140SFT1G	D1, D2
9	1	MBRA340T3G	MBRA340T3G	D3
10	1	15 μ H	MSS1048T-153ML	L1
11	1	CON1		MNT1
12	1	CON1		MNT2
13	1	CON1		MNT3
14	1	CON1		MNT4
15	1	NTD5807	NTD5802NT4G	Q1
16	1	21.5k		R1
17	1	80 m Ω	WSL1206R0800FEA	R2
18	1	78.7k		R3
19	1	10K		R4
20	1	VSW		TP1
21	1	VOUT		TP2
22	1	VIN		TP3
23	1	VDRV		TP4
24	1	GDRV		TP5
25	1	VIN		TP6
26	1	VC		TP7
27	1	ISNS		TP8
28	1	GND		TP9
29	1	GND		TP10
30	1	VFB		TP11
31	1	EN/SYNC		TP12
32	1	VOUT		TP13
33	1	GND		TP14
34	1	GND		TP15
35	1	GND		TP16
36	1	GND		TP17
37	1	NCV8871	NCV887100D1R2G	U1

onsemi, **Onsemi**, and other names, marks, and brands are registered and/or common law trademarks of Semiconductor Components Industries, LLC dba "**onsemi**" or its affiliates and/or subsidiaries in the United States and/or other countries. **onsemi** owns the rights to a number of patents, trademarks, copyrights, trade secrets, and other intellectual property. A listing of **onsemi**'s product/patent coverage may be accessed at www.onsemi.com/site/pdf/Patent-Marking.pdf. **onsemi** is an Equal Opportunity/Affirmative Action Employer. This literature is subject to all applicable copyright laws and is not for resale in any manner.

The evaluation board/kit (research and development board/kit) (hereinafter the "board") is not a finished product and is not available for sale to consumers. The board is only intended for research, development, demonstration and evaluation purposes and will only be used in laboratory/development areas by persons with an engineering/technical training and familiar with the risks associated with handling electrical/mechanical components, systems and subsystems. This person assumes full responsibility/liability for proper and safe handling. Any other use, resale or redistribution for any other purpose is strictly prohibited.

THE BOARD IS PROVIDED BY ONSEMI TO YOU "AS IS" AND WITHOUT ANY REPRESENTATIONS OR WARRANTIES WHATSOEVER. WITHOUT LIMITING THE FOREGOING, ONSEMI (AND ITS LICENSORS/SUPPLIERS) HEREBY DISCLAIMS ANY AND ALL REPRESENTATIONS AND WARRANTIES IN RELATION TO THE BOARD, ANY MODIFICATIONS, OR THIS AGREEMENT, WHETHER EXPRESS, IMPLIED, STATUTORY OR OTHERWISE, INCLUDING WITHOUT LIMITATION ANY AND ALL REPRESENTATIONS AND WARRANTIES OF MERCHANTABILITY, FITNESS FOR A PARTICULAR PURPOSE, TITLE, NON-INFRINGEMENT, AND THOSE ARISING FROM A COURSE OF DEALING, TRADE USAGE, TRADE CUSTOM OR TRADE PRACTICE.

onsemi reserves the right to make changes without further notice to any board.

You are responsible for determining whether the board will be suitable for your intended use or application or will achieve your intended results. Prior to using or distributing any systems that have been evaluated, designed or tested using the board, you agree to test and validate your design to confirm the functionality for your application. Any technical, applications or design information or advice, quality characterization, reliability data or other services provided by **onsemi** shall not constitute any representation or warranty by **onsemi**, and no additional obligations or liabilities shall arise from **onsemi** having provided such information or services.

onsemi products including the boards are not designed, intended, or authorized for use in life support systems, or any FDA Class 3 medical devices or medical devices with a similar or equivalent classification in a foreign jurisdiction, or any devices intended for implantation in the human body. You agree to indemnify, defend and hold harmless **onsemi**, its directors, officers, employees, representatives, agents, subsidiaries, affiliates, distributors, and assigns, against any and all liabilities, losses, costs, damages, judgments, and expenses, arising out of any claim, demand, investigation, lawsuit, regulatory action or cause of action arising out of or associated with any unauthorized use, even if such claim alleges that **onsemi** was negligent regarding the design or manufacture of any products and/or the board.

This evaluation board/kit does not fall within the scope of the European Union directives regarding electromagnetic compatibility, restricted substances (RoHS), recycling (WEEE), FCC, CE or UL, and may not meet the technical requirements of these or other related directives.

FCC WARNING – This evaluation board/kit is intended for use for engineering development, demonstration, or evaluation purposes only and is not considered by **onsemi** to be a finished end product fit for general consumer use. It may generate, use, or radiate radio frequency energy and has not been tested for compliance with the limits of computing devices pursuant to part 15 of FCC rules, which are designed to provide reasonable protection against radio frequency interference. Operation of this equipment may cause interference with radio communications, in which case the user shall be responsible, at its expense, to take whatever measures may be required to correct this interference.

onsemi does not convey any license under its patent rights nor the rights of others.

LIMITATIONS OF LIABILITY: **onsemi** shall not be liable for any special, consequential, incidental, indirect or punitive damages, including, but not limited to the costs of requalification, delay, loss of profits or goodwill, arising out of or in connection with the board, even if **onsemi** is advised of the possibility of such damages. In no event shall **onsemi**'s aggregate liability from any obligation arising out of or in connection with the board, under any theory of liability, exceed the purchase price paid for the board, if any.

The board is provided to you subject to the license and other terms per **onsemi**'s standard terms and conditions of sale. For more information and documentation, please visit www.onsemi.com.

PUBLICATION ORDERING INFORMATION

LITERATURE FULFILLMENT:

Email Requests to: orderlit@onsemi.com

onsemi Website: www.onsemi.com

TECHNICAL SUPPORT

North American Technical Support:

Voice Mail: 1 800-282-9855 Toll Free USA/Canada

Phone: 011 421 33 790 2910

Europe, Middle East and Africa Technical Support:

Phone: 00421 33 790 2910

For additional information, please contact your local Sales Representative