

## A User's Guide to IC Instrumentation Amplifiers

by Jeffrey R. Riskin

### INTRODUCTION

It is traditional to begin a discussion of instrumentation amplifiers by saying that an IA is not an operational amplifier. As obvious as this statement is to the informed user, and as awkward as a description by exclusion may be, such an approach is inevitable and perhaps necessary. When an engineer needs a signal conditioning gain block, the first thought that springs to mind is the nearly ultimate flexibility provided by the currently available assortment of low-cost IC op amps. It may well be that an op amp will suffice as an element in a given gain block, but in demanding applications, op amp circuitry will often require extensive and expensive additional circuit elements, specialized manufacturing and/or test instrumentation together with highly skilled personnel to make it all work. The purpose of this article is to explain when and where an instrumentation amplifier may best be employed and where its unique virtues give it an advantage over the more flexible op amp.

### WHAT IS AN INSTRUMENTATION AMPLIFIER?

An instrumentation amplifier is a precision differential voltage gain device that is optimized for operation in an environment hostile to precision measurement. The real world is characterized by deviations from the ideal; temperature fluctuates, electrical noise exists, and voltage drops caused by current through the resistance of leads from remote locations are dictated by the laws of physics. Furthermore, real transducers rarely exhibit zero output impedance and nice neat zero-to-ten-volt ranges. Induced, leaked or coupled electrical interference (noise) is always present to some extent. In brief, even the best "cookbook" must be taken with a grain of salt.

Instrumentation amplifiers are intended to be used whenever acquisition of a useful signal is difficult. IA's must have extremely high input impedances because source impedances may be high and/or unbalanced. Bias and offset currents are low and relatively stable so that the source impedance need not be constant. Balanced differential inputs are provided so that the signal source may be referenced to any reasonable level independent of the IA output load reference. Common mode rejection, a measure of input balance, is very high so that noise pickup and ground drops, characteristic of remote sensor applications, are minimized.

Care is taken to provide high, well-characterized stability of critical parameters under varying conditions, such as changing temperatures and supply voltages. Finally, all components that are critical to the performance of the IA are internal to the device (with the exception of a single gain-determining resistor or resistor-pair). The manufacturer may then optimize, characterize and guarantee the specifications, while the user may in turn depend on a certain level of performance without having to provide his own precision application components or design expertise.

The precision of an IA is provided at the expense of flexibility. By committing to the one specific task of amplifying voltage, the IA manufacturer may optimize performance in this area. An IA is not intended to perform integration, differentiation, rectification, or any other non-voltage-gain function; although possible with an IA, these tasks are best left to operational amplifiers.

To put an instrumentation amplifier to work, the potential user does not require an intimate knowledge of its internal construction. Figure 1, a functional diagram of a basic IA, provides sufficient information for many applications.

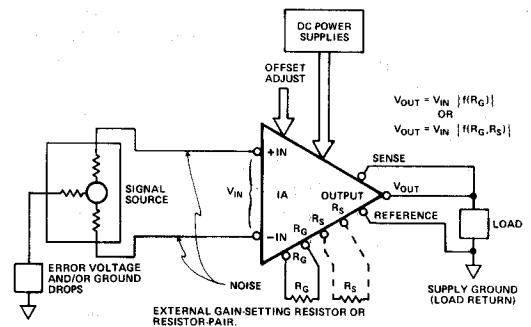

*Figure 1. Basic Instrumentation Amplifier Functional Diagram*

The two inputs shown permit direct interface to "floating" signal sources. The IA, being truly differential, detects only the difference in voltage between its inputs; any common-mode signals (signals present on both inputs), such as noise

and voltage drops in ground lines, are subtracted and cancelled at the inputs before amplification takes place.\*

A single resistor or resistor-pair is used to program the IA for the desired gain. The manufacturer will provide a transfer function or gain equation that allows the user to calculate the required values of resistance for a given gain. Special requirements for that resistor or resistors, if any, are also spelled out by the manufacturer.

The output is single-ended and is designed to drive ground-referenced loads as normally found in measurement equipment. The load reference is common to the power supply return although careful consideration must be given to the overall grounding system (more on that later).

Of course, power must be supplied to the IA; as with op amps, this is normally a differential balanced voltage that may be varied over a specified range.

Most instrumentation amplifiers provide some means of adjusting offset voltage (that dc error voltage present at the output when both inputs are grounded). This adjustment is usually made by varying the setting of an external potentiometer. Sense and reference terminals allow remote sensing of output voltage so that effects of IR drops and ground drops may be minimized. For low current non-remote loads, the sense terminal may be tied directly to the output while the reference terminal may be tied to power supply common. There are other uses for sense and reference that will be discussed in the applications section of this article.

### INSIDE AN INSTRUMENTATION AMPLIFIER

While there are many ways of designing an instrumentation amplifier, most such designs can be classified into one of two categories. The most common configuration consists of a number of interconnected operational amplifiers and a precision resistor network. This technique is popular in modular and hybrid instrumentation amplifiers where most practical designs utilize a minimum number of components.

In the other category are designs that, instead of employing op amps, use fundamental active-circuit elements, such as differential circuits and controlled current sources and reflectors; this eliminates all unnecessary or redundant features and tends to minimize active device (transistor) count and decrease the dependence upon accurate resistor matching. This technique is most often employed in the design of monolithic IA's where cost is inversely proportional to chip size. Some older modular IA's also use this technique because suitably precise IC op amps have only recently become readily available. Newer modular IA's may also use this technique because nonlinearity tends to be lower at high gains, although some sacrifice of linearity may exist at lower gains.

#### Op Amp Based IA's

The most simple (and crude) method of implementing a differential gain block with op amps is shown in Figure 2.

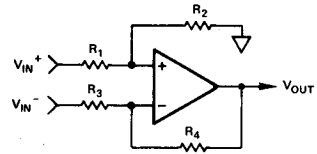

$$V_{OUT} = V_{IN}^+ \left( \frac{R_2}{R_1 + R_2} \right) \left( \frac{R_3 + R_4}{R_3} \right) - V_{IN}^- \left( \frac{R_4}{R_3} \right)$$

Figure 2. Differential Input Voltage Gain Block (Simple Subtractor)

In this circuit, an expressions for  $V_{OUT}$  can be derived by superposition.

The output for  $V_{IN}^+$  ( $V_{IN}^-$  grounded) is:

$$V_{O1} = V_{IN}^+ \left( \frac{R_2}{R_1 + R_2} \right) \left( \frac{R_3 + R_4}{R_3} \right) \quad (1)$$

The output for  $V_{IN}^-$  ( $V_{IN}^+$  grounded) is:

$$V_{O2} = -V_{IN}^- \left( \frac{R_4}{R_3} \right) \quad (2)$$

By superposition:

$$\begin{aligned} V_O &= V_{O1} + V_{O2} \\ &= V_{IN}^+ \left( \frac{R_2}{R_1 + R_2} \right) \left( \frac{R_3 + R_4}{R_3} \right) - V_{IN}^- \left( \frac{R_4}{R_3} \right) \end{aligned} \quad (3)$$

If  $R_2 = R_4$ ,  $R_1 = R_3$ :

$$V_O = (V_{IN}^+ - V_{IN}^-) \frac{R_4}{R_3} \quad (4)$$

Thus, we have created a simple differential voltage amplifier. The input impedances, however, are low and unequal. Furthermore, all 4 resistors have to be carefully ratio-matched to maintain good common mode rejection:

$$\begin{aligned} V_{OUT\ CM} &= V_{OUT} \text{ for } V_{IN}^+ = V_{IN}^- \\ &= V_{IN} \left[ \left( \frac{R_2}{R_1 + R_2} \right) \left( \frac{R_3 + R_4}{R_3} \right) - \left( \frac{R_4}{R_3} \right) \right] \end{aligned} \quad (5)$$

If we are looking for a gain of 1, all resistors will be equal. For a 0.1% mismatch in just one of the resistors:

$$R_1 = R_3 = R_4 = R$$

$$R_2 = 0.999R$$

$$\begin{aligned} V_{O\ CM} &= V_{IN} \left[ \left( \frac{0.999R}{1.999R} \right) \left( \frac{2R}{R} \right) - \left( \frac{R}{R} \right) \right] \\ &= 0.0005V_{IN} \end{aligned} \quad (6)$$

$$CMR = 66\text{dB}$$

\*For applications involving extremely high common-mode voltages, or requiring complete galvanic isolation, isolation amplifiers should be used. Analog Devices manufactures a complete line of single and multi-channel isolators.

(Note that if the source resistance is not low and balanced, gain and CMR will be further degraded.)

Considering what is available in the way of reasonably priced standard resistors, one can hardly expect to improve upon this mediocre level of performance. Considering the several serious drawbacks, it is not surprising that this configuration is not used in true instrumentation amplifier designs.

The two-amplifier approach shown in Figure 3 overcomes some of the weaknesses inherent in the simple subtractor of Figure 2.

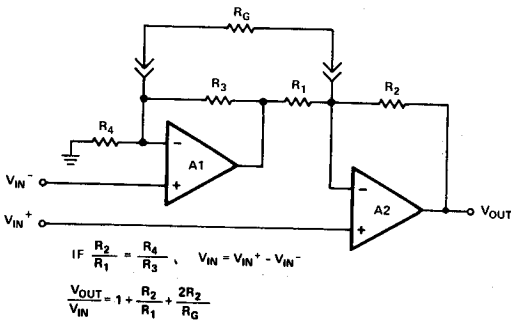

Figure 3. "Two-Amplifier" Instrumentation Amplifier

Input resistance is high, thus permitting the signal sources to have unbalanced, non-zero output impedance. Furthermore, gain may be changed by switching only one resistor thus allowing CMR to remain constant once initial trimming is accomplished. (CMR is still dependent upon the ratio-matching of four resistors.) The major disadvantage to this design is that the common mode voltage input range is a function of gain and can thus be very poor. By referring to Figure 3, it can be seen that A1 is called upon to amplify a common mode signal by the ratio  $(R_3 + R_4)/R_4$ ; this could lead to saturation of A1 thus leaving no "headroom" to amplify the differential signal of interest. A few modules and hybrids use this configuration because of its simplicity, but it is not optimal.

The most popular configuration for op-amp based instrumentation amplifiers is shown in Figure 4:

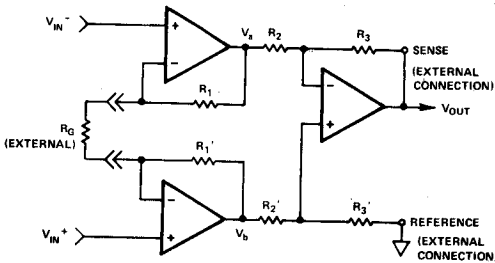

Figure 4. "Classic" 3 Op Amp Instrumentation Amplifier

The transfer function of this circuit can be calculated by superposition.

For  $V_{IN}^- = 0$

$$V_a = V_{IN}^+ \left( \frac{R_1 + R_G}{R_G} \right) \quad (7)$$

$$V_b = V_{IN}^+ \left( \frac{R_1'}{R_G} \right) \quad (8)$$

For  $V_{IN}^- = 0$

$$V_a = V_{IN}^+ \left( \frac{R_1}{R_G} \right) \quad (9)$$

$$V_b = V_{IN}^+ \left( \frac{R_1' + R_G}{R_G} \right) \quad (10)$$

$$\therefore V_a = V_{IN}^+ \left( \frac{R_1 + R_G}{R_G} \right) - V_{IN}^+ \left( \frac{R_1}{R_2} \right) \quad (11)$$

$$\text{and } V_b = V_{IN}^+ \left( \frac{R_1' + R_G}{R_G} \right) - V_{IN}^+ \left( \frac{R_1'}{R_2} \right) \quad (12)$$

$$V_{OUT} = - \left( \frac{R_3}{R_2} \right) V_a + V_b \left( \frac{R_3'}{R_2 + R_3'} \right) \left( \frac{R_3 + R_2}{R_2} \right) \quad (13)$$

If  $R_3 = R_3'$ ,  $R_2 = R_2'$ , and  $R_1 = R_1'$

$$V_{OUT} = (V_b - V_a) \left( \frac{R_3}{R_2} \right) \quad (14)$$

substituting for  $V_b$  and  $V_a$  and simplifying

$$V_{OUT} = (V_{IN}^+ - V_{IN}^-) \left( \frac{2R_1}{R_G} + 1 \right) \left( \frac{R_3}{R_2} \right) \quad (15)$$

In this configuration, gain accuracy and CMR still depends upon the ratio-matching of  $R_2$ ,  $R_2'$ ,  $R_3$  and  $R_3'$ . It can be shown, however, that CMR does *not* depend on the matching of  $R_1$  and  $R_1'$ .

$$V_{CM\ OUT} = (V_a - V_b) = V_{IN}^+ \left( \frac{R_1' + R_G}{R_G} \right) - V_{IN}^- \left( \frac{R_1'}{R_G} \right) - V_{IN}^- \left( \frac{R_1 + R_G}{R_G} \right) + V_{IN}^+ \left( \frac{R_1}{R_G} \right) \quad (16)$$

but  $V_{CM\ IN} = V_{IN}^+ = V_{IN}^-$

$$V_{CM\ OUT} = V_{CM\ IN} \left[ \frac{R_1' + R_G}{R_G} - \frac{R_1'}{R_G} - \frac{R_1 + R_G}{R_G} + \frac{R_1}{R_G} \right] \quad (17)$$

$$= V_{CM\ IN} \left[ \frac{R_1'}{R_G} - \frac{R_1'}{R_G} + 1 - \frac{R_1}{R_G} + \frac{R_1}{R_G} - 1 \right] \quad (18)$$

$$= V_{CM\ IN} [0]$$

$$= 0$$

Therefore, in theory at least, the user may take as much gain in the front end as he wishes (as determined by  $R_G$ ) without increasing the common mode error signal. Thus, CMRR will theoretically increase in direct proportion to gain, a very useful property. Furthermore, common-mode signals are only amplified by a factor of 1 regardless of gain because no common-mode voltage will appear across  $R_G$ , hence, no common-mode current will flow in it (the input terminals of an op-amp operating normally will have no significant potential difference between them). This means that large common-mode signals may be handled independent of gain.

Finally, because of the symmetry of this configuration, first order common-mode error sources in the input amplifiers, if they track, tend to be cancelled out by the output stage subtractor. These features explain the popularity of this IA design technique.

IA's of this type may use either FET or Bipolar input operational amplifiers. FET input devices have very low bias currents and are well-suited for use with very high source impedances. FET input op amps, however, generally have poorer CMR than bipolar amplifiers due to non-geometry related mis-matches. (In other words, matching of FET's is largely a function of process control; matching bipolar transistors is less process dependent.) This will manifest itself in lower linearity and CMR for large input voltages. Furthermore, these mis-matches usually cause larger input offset voltage drifts. For these reasons, Analog Devices instrumentation amplifiers use bipolar input stages thus sacrificing low bias currents to achieve high linearity and CMR along with low input offset voltage drift. As technology develops, FET input IA's may become more viable.

### Dedicated Design IA's

The second category of IA design is based on minimum active device count; a virtue for monolithic IC circuits. The basic schematic for such a design is shown in Figure 5.

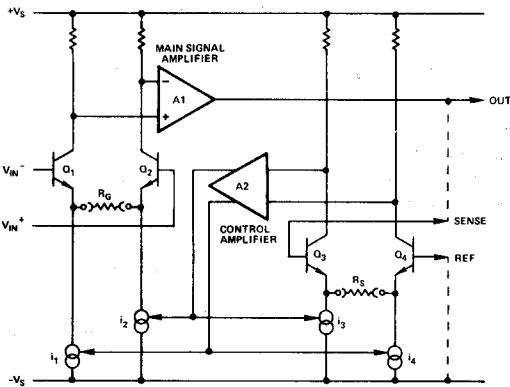

Figure 5. Typical IC IA Basic Schematic

Forward gain is provided by the input differential stage  $Q_1$  and  $Q_2$  whose current gain (transconductance) is  $1/R_G$  (amps/volt) and the main signal amplifier  $A_1$  which senses differences in input stage collector currents. When the output is connected back to sense (with reference grounded) differential stage  $Q_3$  and  $Q_4$  acts as a feedback error-sensing amplifier with a transconductance of  $1/R_S$  (amps/volt).  $A_2$  senses the collector current imbalance in that stage.

When a differential voltage is applied to the inputs, the collector currents of  $Q_1$  and  $Q_2$  tend to become unbalanced by  $(V_{IN}^+ - V_{IN}^-)/R_G$ . This is sensed by  $A_1$  which develops an error voltage between the sense and reference points. This, in turn, tries to unbalance the collector currents in  $Q_3$  and  $Q_4$  by  $(V_{SENSE} - V_{REF})/R_S$ . That unbalance is sensed by  $A_2$  which then adjusts  $I_3$  and  $I_4$  to equalize the collector currents in  $Q_3$  and  $Q_4$  ( $I_4 - I_3 = (V_S - V_R)/R_S$ ).  $A_2$  simultaneously adjusts  $I_1$  and  $I_2$  such that  $I_1 - I_2 = I_4 - I_3$ . Balance is reached when:

$$\frac{V_S - V_R}{(I_4 - I_3) R_S} = \frac{V_1 - V_2}{(I_1 - I_2) R_G} \quad (19)$$

$$\text{if } \frac{V_S - V_R}{V_1 - V_2} = \frac{V_{OUT}}{V_{IN}} = \text{Gain} \quad (20)$$

$$\text{and } I_4 - I_3 = I_1 - I_2$$

$$\text{Gain} = \frac{R_{SCALE}}{R_{GAIN}} \quad (21)$$

It is apparent from this analysis that the requirement for carefully matched resistors changes to a requirement for carefully matched active devices. In IC technology, this is possible by utilization of precision photographic techniques along with careful design layout and well-controlled processing. The result is a good trade-off between high performance and low cost.

### INSTRUMENTATION AMPLIFIER SPECIFICATIONS

To successfully apply any electronic component, a full understanding of its specifications is required. That is to say, the numbers contained in a spec sheet are of little value if the user doesn't have a clear picture of what each spec means. In this section, a typical instrumentation amplifier specification sheet will be reviewed. Each individual specification will be discussed in terms of how it is measured and what error it might contribute to the overall performance of the circuit. In some cases, a given specification may not affect a particular application; the more common situations of this type will be discussed.

At the top of the spec sheet is the statement that the listed specs are typical @  $V_S = \pm 15V$ ,  $R_L = 2k\Omega$  and  $T_A = +25^\circ C$  unless otherwise specified. This tells the user that these are the normal operating conditions under which the device is tested. Deviations from these conditions might degrade (or improve) performance. When deviations from the "normal" conditions are likely (such as a change in temperature) the significant effects are usually indicated within the specs. This statement also tells us that all numbers are typical unless noted; "typical" means that the manufacturers characterization process has shown this number to be average, but individual devices may vary.

Specifications not discussed in detail are self-explanatory and require only a basic knowledge of electronic measurements. Those specs do not apply uniquely to instrumentation amplifiers.

#### Gain

These specs relate to the transfer function of the device.

$$\text{Gain Equation: } G = 1 + \frac{2(10^5)}{R_G} \quad (22)$$

To select an  $R_G$  for a given gain, solve the equation for  $R_G$

$$\text{(in ohms): } R_G = \frac{200,000}{G - 1} \quad (23)$$

For example:

- G = 1 :  $R_G = \infty$  (open circuit)
- G = 10 :  $R_G = 22,222\Omega$
- G = 100 :  $R_G = 2020.2\Omega$
- G = 1000 :  $R_G = 200.20\Omega$

Of course the user must provide a very clean circuit board to realize an accurate gain of 1 since 200M $\Omega$  leakage resistance will cause a gain error or 0.1%.

**Gain Range**

Specified at 1 to 1000, this device may (and in fact will) work at higher gains, but the manufacturer will not promise any particular level of performance. In practice, noise and drift may make higher gains impractical for this device.

**Equation Error**

The number given by this specification describes maximum deviation from the gain equation. The user can trim the gain (above unity) or can compensate elsewhere in his design. If his data is eventually digitized and fed to an "intelligent system" (such as a microprocessor), he might be able to correct for gain errors by measuring a reference and multiplying by a constant.

**Nonlinearity**

Nonlinearity is defined as the deviation from a straight line on the plot of output versus input. Figure 6a shows the transfer function of a device with exaggerated nonlinearity. The magnitude of this error can be calculated thus:

$$N. L. = \left[ \frac{\text{Actual Output} - \text{Calculated Output}}{\text{Rated Full-Scale Output Range}} \right]$$

To confuse matters, this deviation can be specified relative to any straight line or to a specific straight line. There are two commonly-used methods of specifying this ideal straight line relative to the performance of a precision measurement device.

The "Best Straight Line" method of nonlinearity specification consists of measuring the peak positive and negative deviations and adjusting the slope of the device transfer function (by adjusting the gain and offset) so that these maximum positive and negative errors are equal. This method yields the best specifications but is difficult to implement in that it requires that the user examine the entire output signal range to determine these maximum positive and negative deviations. The results of a best-straight-line calibration is shown by the transfer function of Figure 6b.

The "End-Point" method of specifying nonlinearity requires that the user perform his offset and/or gain calibrations at the extremes of the output range. This is much easier to implement but may result in nonlinearity errors of up to twice these attained with best-straight-line techniques. This worst case will occur when the transfer function is "bowed" in one direction only. Figure 8c shows the results of end-point calibration.

Most linear devices, such as instrumentation amplifiers, are specified for best-straight-line linearity. The user must take this into consideration when evaluating the error budget for his application.

Regardless of the method used to specify nonlinearity, the errors thus created are irreducible. That is to say that these errors are neither fixed nor proportional to input or output voltage and can not be reduced by adjustment.

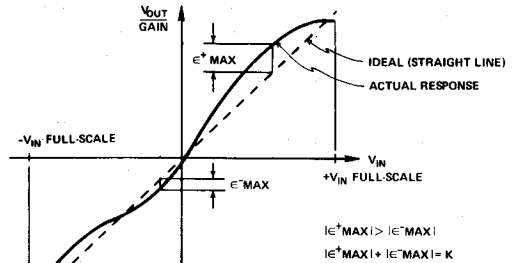

a.) Transfer Function Illustrating Exaggerated Nonlinearity

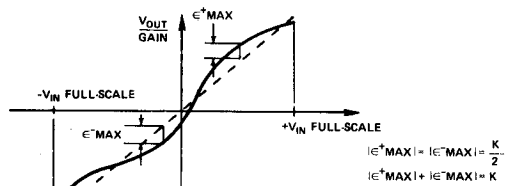

b.) Transfer Function a.) After Calibration by Best-Straight-Line Method

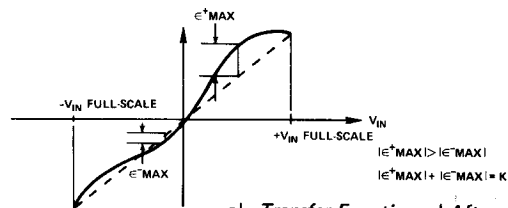

c.) Transfer Function a.) After Calibration by End-Point Method

Figure 6. Nonlinear Transfer Function

**Gain vs. Temperature**

These numbers give both maximum and typical deviations from the gain equation as a function of temperature. An intelligent system can correct for this with an "auto-gain" cycle (measure a reference and re-normalize).

**Setting Time**

Setting time is defined as that length of time required for the output voltage to approach and remain within a certain tolerance of its final value. It is usually specified for a fast full scale input step and includes output slewing time. Since several factors contribute to the overall settling time, fast settling to 0.1% doesn't necessarily mean proportionally fast-settling to 0.01%. In addition, settling time is not necessarily a function of gain. Some of the contributing factors

include slew rate limiting, under-damping (ringing) and thermal gradients ("long tails").

### Voltage Offset

Voltage offset specifications are often considered a figure of merit for instrumentation amplifiers. While initial offset may be adjusted to zero, shifts in offset voltage could cause errors. Intelligent systems can often correct for this factor with an auto-zero cycle, but there are many small-signal high-gain applications that don't have this capability.

Voltage offset and offset drift comprise two components each; input and output offset and offset drift. Input offset is that component of offset that is directly proportional to gain, i.e., input offset as measured at the output at  $G = 100$  is 100 times greater than at  $G = 1$ . Output offset is independent of gain. At low gains, output offset drift is dominant, while at high gains input offset drift dominates. Therefore, the output offset voltage drift is normally specified as drift at  $G = 1$  (where input effects are insignificant), while input offset voltage drift is given by drift specification at a high gain (where output offset effects are negligible). All input-related numbers are referred to the input (RTI) which is to say that the effect on the output is "G" times larger. Voltage offset vs. power supply is also specified at one or more gain settings and is also RTI.

### Input Bias Currents

Input bias currents are those currents necessary to bias the input transistors of a dc amplifier. FET input devices have lower bias currents, but those currents increase dramatically with temperature, doubling approximately every  $11^{\circ}\text{C}$ . Since bias currents can be considered as a source of voltage offset (when multiplied by source resistance), the change in bias currents is of more concern than the magnitude of the bias currents. Input offset current is the difference between the two input bias currents.

Although instrumentation amplifiers have differential inputs, there must be a return path for the bias currents. If this is not provided, those currents will charge stray capacitances, causing the output to drift uncontrollably or to saturate. Therefore, when amplifying "floating" input sources such as transformers and thermocouples, as well as ac-coupled sources, there must still be a dc path from each input to ground.

### Common-Mode Rejection

Common-mode rejection is a measure of the change in output voltage when both inputs are changed equal amounts. These specifications are usually given for a full-range input voltage change and a specified source imbalance. "Common-mode rejection ratio" (CMRR) is a ratio expression while "common-mode rejection" (CMR) is the logarithm of that ratio. For example, a CMRR of 10,000 corresponds to a CMR of 80dB.

In most IA's the CMRR increases with gain. This is because most designs have a front-end configuration that does not amplify common-mode signals. Since the standard for CMRR specifications is referred to the output (RTO), a gain for differential signals in the total absence of gain for common-mode output signals will yield a 1-to-1 improvement of CMRR with gain. This means that the common-mode output error signal will not increase with gain, it does not mean that it decreases with gain! At higher gains, however, amplifier bandwidth decreases. Since differences in phase-shift through the differential input stage will show up as a

common-mode error, CMRR becomes more frequency dependent at high gains.

### Error Budget Analysis

To illustrate how instrumentation amplifier specifications are applied, we will now examine a typical case where an AD522 is required to amplify the output of an unbalanced transducer.

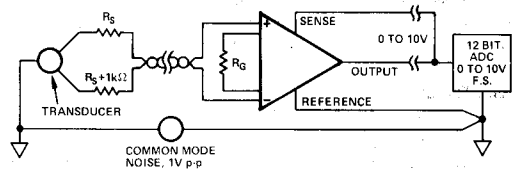

Figure 7. Typical IA Application

Figure 7 shows a differential transducer, unbalanced by  $1\text{k}\Omega$ , supplying a 0 to 1 volt signal to a remotely located IA. The output of the IA feeds a 12 bit A to D converter with a 0 to 10 volt input voltage range. There is 1 volt of peak-to-peak 0 to 10Hz noise on the ground return appearing as a common-mode signal at the inputs of the IA. The operating temperature range is  $-25^{\circ}\text{C}$  to  $+85^{\circ}\text{C}$ ; calibration is performed at  $+25^{\circ}\text{C}$ .

The input signal must be amplified by a factor of 10 in order to utilize the full resolution of the A to D converter. Solving the gain equation for  $G = 10$  gives a value of  $22.22\text{k}\Omega$  for  $R_G$ .

Table 2 lists all applicable error sources and their corresponding effects on accuracy. Initial errors are defined as those errors that can be reduced to a negligible amount by performance of an initial calibration.

Reducible errors include these initial errors along with other errors that occur during normal operation that may be corrected by an adaptive or "intelligent" system. For example, changes in gain or offset may be measured during an auto-zero/auto-gain cycle by measuring two known voltages (a precision reference and ground, for example). This is a common practice in computer or processor-controlled equipment.

Irreducible errors are errors which can not be readily corrected either at initial calibration or in use. It could be argued that an array of precision references would permit a software linearity correction, but in most applications that would be unrealistically cumbersome.

The total error "as built" is approximately 5540ppm or 0.55%. If an initial calibration is performed, this number is reduced by  $2210\text{ppm}$  to  $3330\text{ppm} = 0.33\%$ . Note that 3000ppm of this is gain drift.

In many applications, differential linearity and resolution are of prime importance. This would be so in cases where the absolute value of a variable is less important than changes in value. In these applications, only the irreducible errors ( $57.8\text{ppm} = 0.006\%$ ) are significant. Furthermore, if a system has an intelligent processor monitoring the A to D output, the addition of a auto-gain/auto-zero cycle will remove all reducible errors and may eliminate the requirement for initial calibration. This will also reduce errors to 0.006%.

In the above example, the system can justifiably make use of a 13 bit A to D converter for its differential linearity and

resolution. Dynamic range exceeds 84dB (14 bits). Absolute accuracy depends on calibration and system interaction capabilities; it might be as good as the resolution (0.006%) or as poor as the initial accuracy (0.55%).

## INSTRUMENTATION AMPLIFIER APPLICATIONS

### General Considerations

Whenever a precision high-gain device—such as an instrumentation amplifier—is used, certain precautions apply. Obviously, it is wise to have a clean layout, short wire runs where possible and a carefully considered grounding scheme. Figure 8 shows a well-thought out approach to IA interconnection.

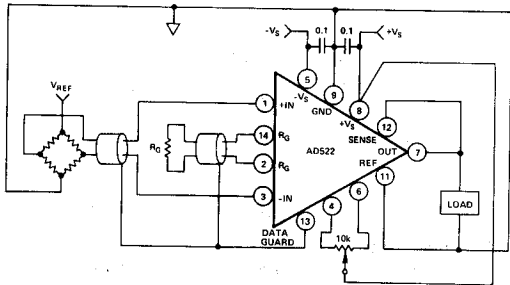

Figure 8. AD522 Interconnection

A properly designed instrumentation amplifier exhibits low sensitivity to power supply variations; the AD522, for example, shows an RTI offset variation of only  $0.2\mu\text{V}$  per percent of power supply change at  $G = 1000$ . At increasing frequencies, however, this rejection factor will degrade as internal capacitances permit more power supply noise to find its way into the signal path. This effect can be minimized by bypassing the power supplies, as close to the IA as possible, with  $0.1\mu\text{F}$  ceramic disc capacitors. Larger tantalum capacitors would be effective against lower frequency variations, but a competent IA is capable of rejecting most of these slower changes.

The offset adjustment pot usually affects the balance of the high gain differential input stage. Short wire runs to this pot will minimize injection of noise into a sensitive location.

The gain-determining resistor,  $R_G$ , is often remotely located for purposes of gain switching. A well-designed IA will tolerate this to a certain extent, but stray capacitances and wiring inductance may disturb the frequency compensation of the device. Sometimes it becomes necessary to install a series RC right at the  $R_G$  terminals of the IA to add a compensating zero to correct for LC resonances caused by stray inductances and capacitances. This lead compensation may improve stability at the cost of a peak in the frequency response curve at the high end. Unfortunately, this compensation, if required, depends on the individual application and is usually determined experimentally.

Most IA's are provided with "sense" and "reference" outputs. While there are several interesting uses for these features (to be discussed later), the most basic application is remote load sensing. This essentially puts the IR drops "inside the loop" of the IA and is most useful when driving remote and/or heavy loads or when the load ground is not firmly "anchored" to the power supply returns.

Grounding is a topic worthy of its own application note (see "An IC Amplifier User's Guide to Decoupling, Grounds,

etc." by A. P. Brokaw). In the case of instrumentation amplifiers, the main thing to remember is that all signal and power returns must eventually have a direct or indirect common point. Direct coupling of IA inputs make it necessary to provide signal ground returns for input amplifier bias currents. Figure 8 shows a direct connection. If a "floating" source or ac coupling is used, indirect returns similar to those shown in Figure 9 must be provided.

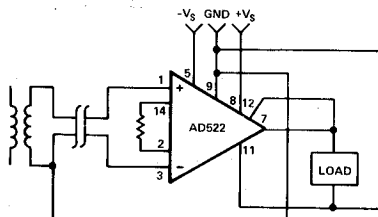

a). Transformer Coupled

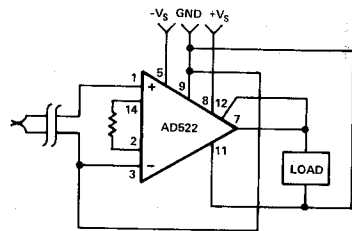

b). Thermocouple

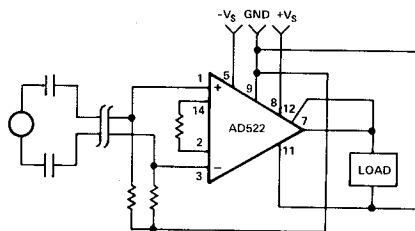

c). AC Coupled

Figure 9. Indirect Ground Returns for "Floating" Transducers

Signals from remote transducers are often transmitted to the IA through shielded cables. While this may well serve to reduce noise pick-up, the distributed RC's in such cabling can cause differential phase shifts in those lines. When ac common-mode signals are present, these phase shifts will reduce common-mode rejection. The same effect will occur with remote  $R_G$ 's located at the end of shielded cables. If the shields could be driven by the common-mode signal, the cable capacitance could be "boot-strapped" thus making the capacitance effectively zero for common-mode signals. The data guard output of the AD522 provides the common-mode component of the input signals and can be used to drive the shields of coaxial input cables and increase ac CMR. Figure 8 illustrates this connection; if not used, the data guard should be left unconnected.

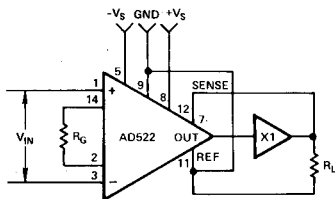

Figure 10. Current-Booster Output

### Boosted Output

In the previous section, use of the sense terminal for remote load sensing was discussed. Another use of that terminal is illustrated in Figure 10.

Typically, IC instrumentation amplifiers are rated for a full  $\pm 10$  volt output swing into  $2k\Omega$ . In some applications, however, the need exists to drive more current into heavier loads. Figure 10 shows how a high-current booster may be connected "inside the loop" of an instrumentation amplifier to provide the required current boost without significantly degrading overall performance. Nonlinearities, offset and gain inaccuracies of the buffer are minimized by the loop gain of the IA output amplifier. Offset drift of the buffer is similarly reduced.

### Offset Load

The reference terminal may be used to offset the output by up to  $\pm 10V$ . This is useful when the load is "floating" or does not share a ground with the rest of the system. It also provides a direct means of injecting a precise offset.

Two caveats apply to the use of the reference pin. When the IA is of the three-amplifier configuration shown in Figure 4 (as is the AD522), it is necessary that nearly zero impedance be presented to the reference terminal. It can be shown that any significant resistance from the reference terminal to ground increases the gain of the non-inverting signal path thereby upsetting the common-mode rejection of the IA. An operational amplifier may be used to provide that low impedance reference point as shown in Figure 11. The input offset voltage characteristics of that amplifier will add directly to the offset voltage performance of the IA.

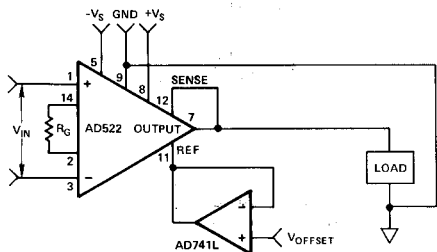

Figure 11. Use of Reference Terminal to Provide Output Offset

The other precaution is more obvious. The output voltage range of an IA is clearly specified; if that range is mostly used up by offset at the reference terminal not much range is left for the signal. In other words, the sum of the offset and signal may not exceed the specified output voltage range of the IA.

### CMR Trim

The effect of resistance in the reference termination may be used to advantage. A short-term CMR improvement can be realized with the circuit shown in Figure 12.

While applying a low-frequency 20 volt peak-to-peak input signal to both inputs, the pot should be adjusted for an output null. In many cases this adjustment will not improve matters on a long-term basis since the common-mode rejection of the device is determined by the long-term stability of internal components (which will drift regardless of what happens externally).

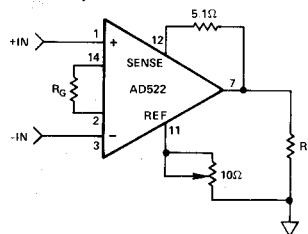
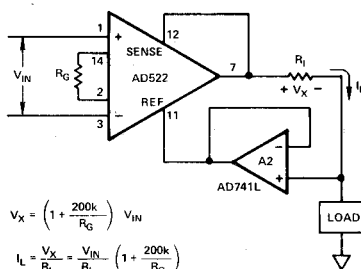

Figure 12. Common Mode Rejection Trim

### Controlled Currents

An instrumentation amplifier can be turned into a voltage-to-current converter by taking advantage of the sense and reference terminals as shown in Figure 13.



$$V_X = \left(1 + \frac{200k}{R_G}\right) V_{IN}$$

$$I_L = \frac{V_X}{R_1} = \frac{V_{IN}}{R_1} \left(1 + \frac{200k}{R_G}\right)$$

Figure 13. Voltage-To-Current Converter

By establishing a reference at the "low" side of a current setting resistor, an output current may be defined as a function of input voltage, gain and the value of that resistor. Since only a small current is demanded at the input of the buffer amplifier  $A_2$ , the forced current  $I_L$  will largely flow through the load. Offset and drift specifications of  $A_2$  must be added to the output offset and drift specifications of the IA.

### CONCLUSIONS

Thus characterized, the instrumentation amplifier stands ready to take its place in the Grand Order of Things. The preliminary contention that an IA is not a special sort of operational amplifier should now be obvious. Its versatility is limited in scope but its applications are limited only by the imagination of the potential user. As a precision linear device, an IA is qualified mainly by its specifications, a full understanding of which is necessary to successfully use it to advantage. Analog Devices, as a long time supplier of components for precision measurement applications, offers a full spectrum of instrumentation amplifiers in modular, hybrid and monolithic IC form, each ideally suited to particular applications. We hope that this article will help clarify the issues involved and will aid in the selection of a suitable device for a particular application.