

# NB3N5573DTGEVB

## NB3N5573DTGEVB Evaluation Board User's Manual



ON Semiconductor®

<http://onsemi.com>

Device Name: NB3N5573DTG (TSSOP-16)  
Board Name: NB35573DTGEVB

### EVAL BOARD USER'S MANUAL

#### Description

The NB3N5573 is a high precision, low phase noise clock generator that supports PCI Express and Ethernet requirements. The device takes a 25 MHz fundamental mode parallel resonant crystal and generates differential HCSL output at 25 MHz, 100 MHz, 125 MHz or 200 MHz clock frequencies.

See datasheet NB3N5573/D ([www.onsemi.com](http://www.onsemi.com)). The NB3N5573DTGEVB Evaluation board is designed to provide a flexible and convenient platform to quickly program, evaluate and verify the performance and operation of the NB3N5573DTG TSSOP-16 (Package Case 948F) device under test: With the device removed, this NB3N5573DTGEVB Evaluation board is designed to accept a 16 Lead TSSOP Socket (M&M Specialties, Inc., 1-800-892-8760, [www.mmspec.com](http://www.mmspec.com), M&M #50-000-00809) to permit use as an insertion test fixture.

#### Board Features

- Crystal mount source, or input external clock source (SMA)
- A TSSOP-16 NB3N5573DTG device is solder mounted or the board may be adapted for insertion testing by adding a TSSOP-16 socket.
- Separate supply connectors for VDD (banana jack and Anvil Clip) and GND (banana jack)

#### Contents

- Description
- Board Features
- Board Layout Maps
- Test and Measurement Setup Procedures
- Appendix 1: Pin to Board Connection Information
- Appendix 2: Schematic
- Appendix 3: Bill of Materials, Lamination Stackup

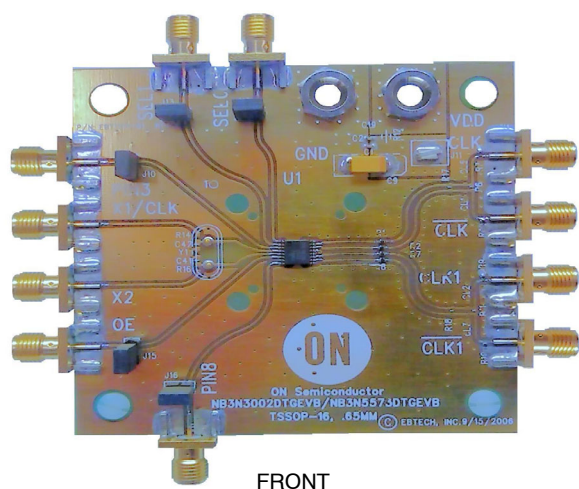

FRONT

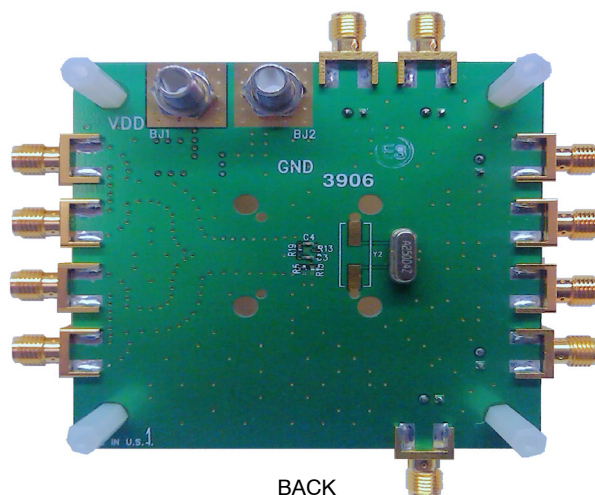

BACK

Figure 1. NB3N5573DTGEVB Evaluation Board

# NB3N5573DTGEVB

## BOARD LAYOUT

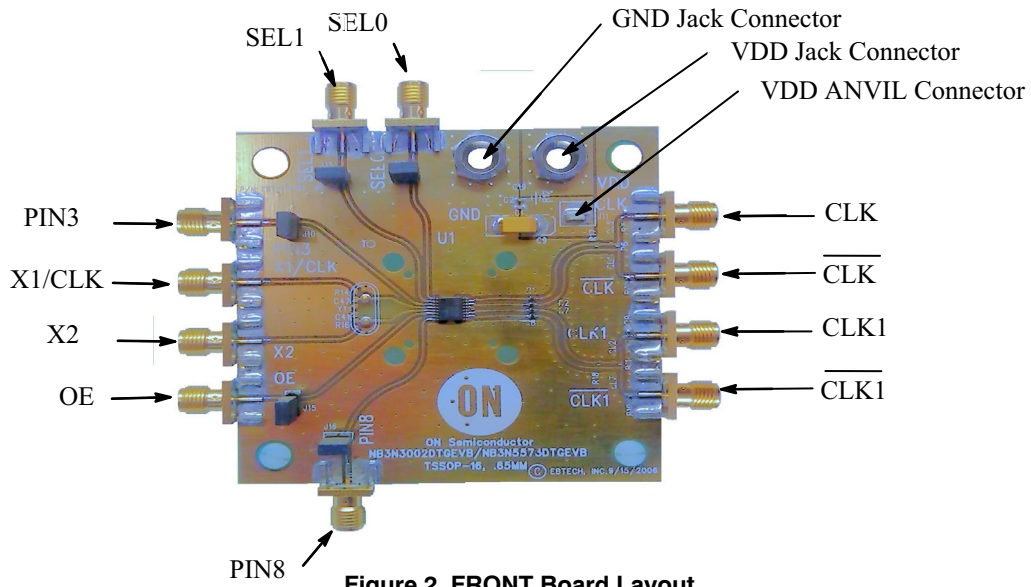

Figure 2. FRONT Board Layout

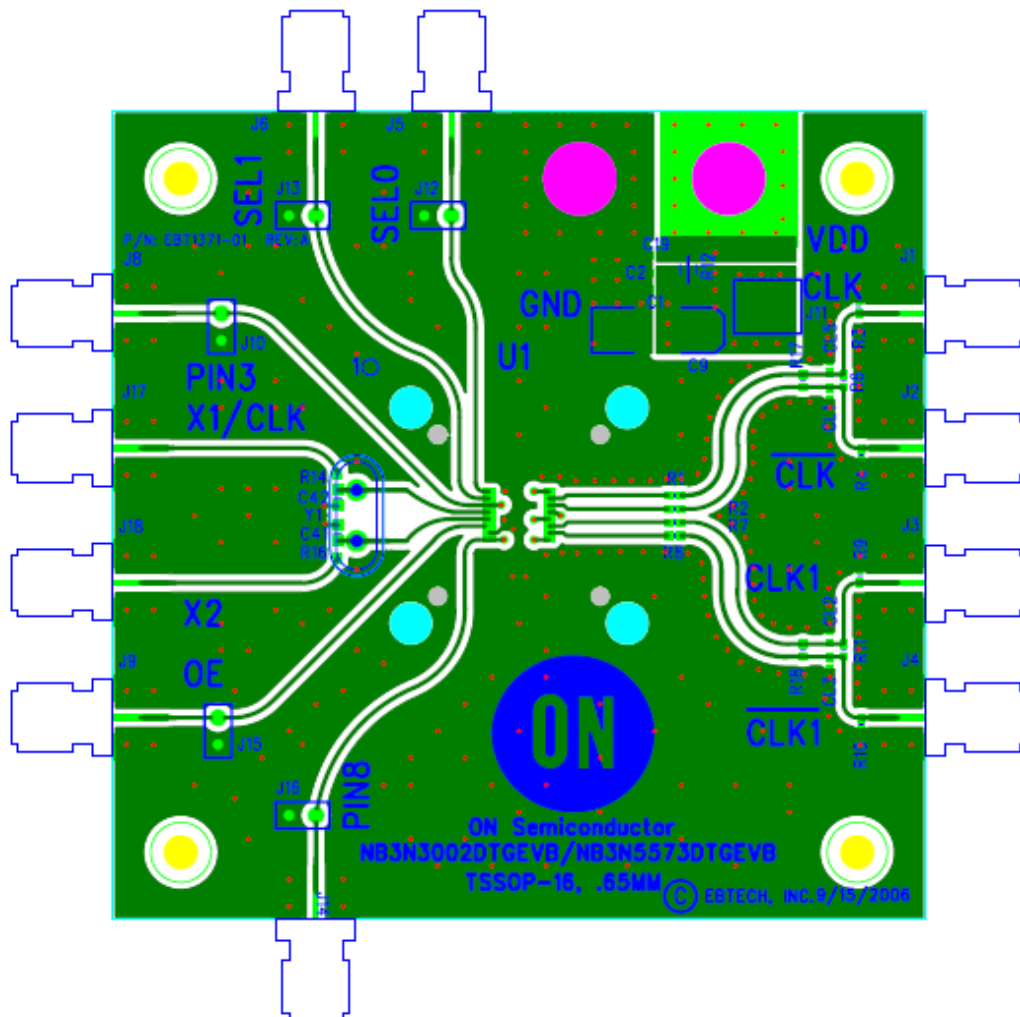

Figure 3. FRONT Layer Design

# NB3N5573DTGEVB

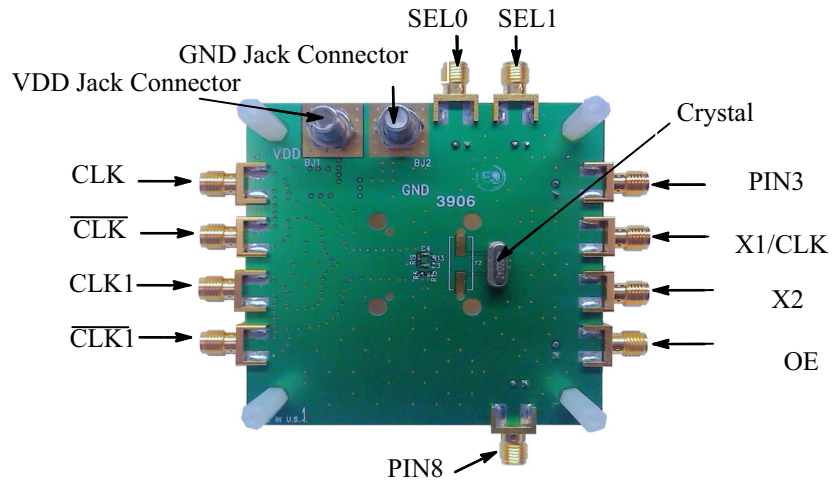

Figure 4. BACK Board Layout

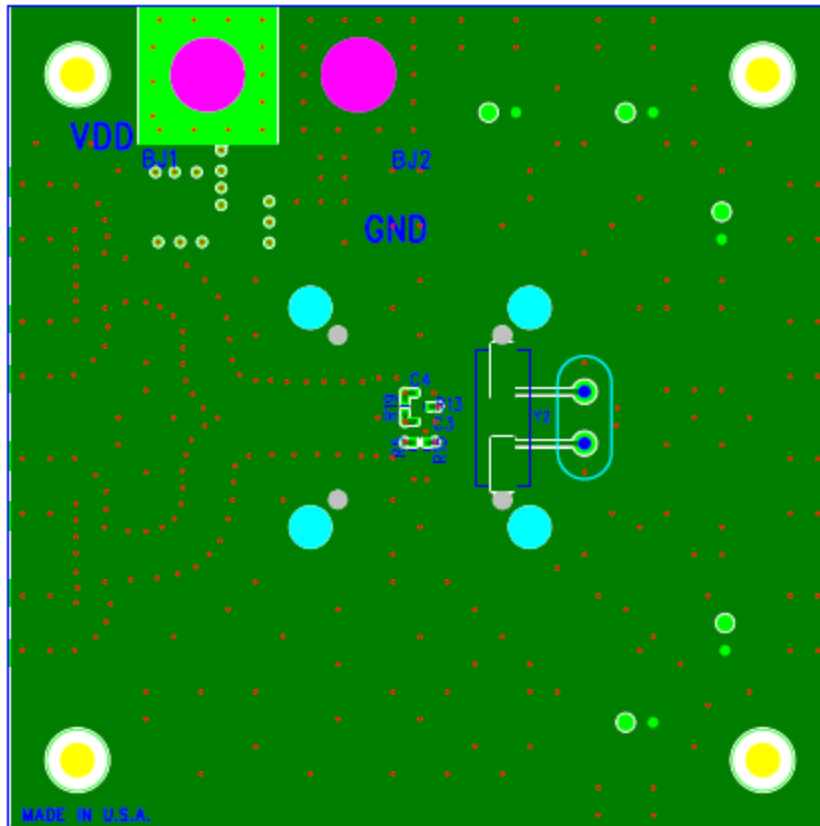

Figure 5. BACK Layer Design

# NB3N5573DTGEVB

## TEST AND MEASUREMENT SET-UP AND PROCEDURE

### Step 1: Equipment

1. Signal Generator: Agilent #33250A or HP8133 (or equivalent)
2. Tektronix TDS8000 Oscilloscope
3. Power Supply: Agilent #6624A or AG6626A DC (or equivalent)
4. Digital Voltmeter: Agilent 34410A or 34401 (or equivalent)
5. Matched Cables (> 20 GHz, SMA connectors): Storm or Semflex (or equivalent)

6. Time Transition Converter: Agilent 14534 250 ps (or equivalent)
7. Phase noise Analyzer: Agilent E5052B (or equivalent)

### Step 2: Lab Set-Up Procedure

1. Test Supply Setup:  
Board and Device Power Supply Connections are shown in Table 1. VDD (Banana Jack or Anvil Clip test point) and GND (Banana Jack) and may be connected by.

**Table 1. POWER SUPPLY CONNECTIONS**

Device	Board	Banana Jack	Anvil Clip Test Point	Comments
VDD	VDD	BJ1	J11	
GND	GND	BJ2	J7	DUTGND and SMA GND

### SUPPLY (VDD = 3.3 V; GND = 0.0 V' VEE = 0.0 V)

Single supply operation may be accomplished by connecting VDD and GND. HCSL CLK, CLKb, CLK1, and

CLK1b outputs are directly connected to a LOW impedance (50 Ω) module, scope, or probe per Figure 6. Both lines in an HCSL pair must be terminated.

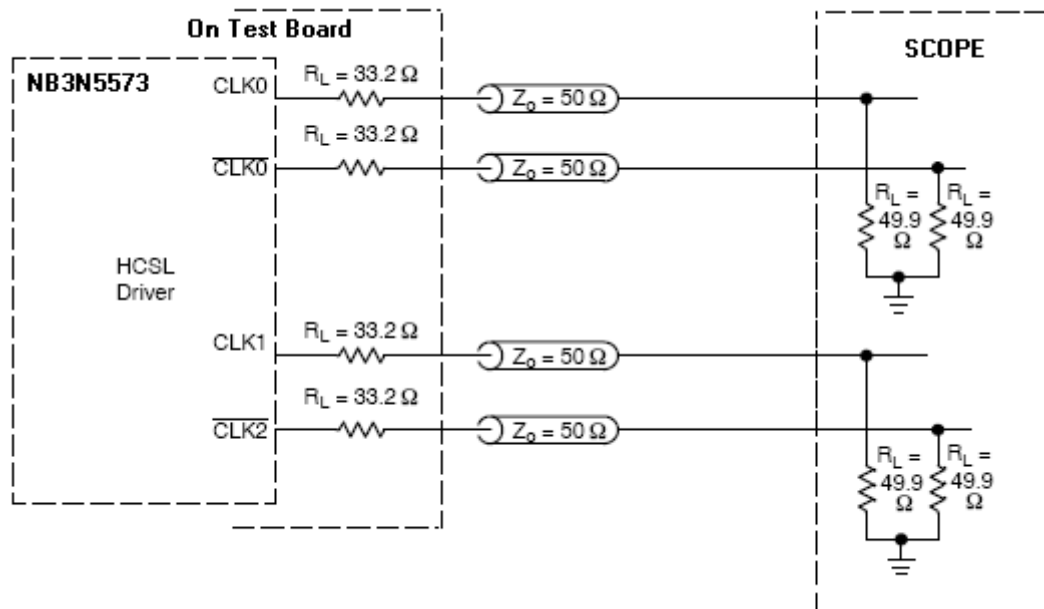

**Figure 6. Typical Termination for Output Driver and Device Evaluation**

2. Inputs: (see Appendix 1, Device Pin to Board Connection Information)

For a Single Ended input to X1/CLK operation, install a zero ohm jumper resistor at R14. Do not install R16. Do not drive X2. Use a LVCMOS Clock amplitude signal at 25 MHz which satisfies datasheet VIH and VIL to drive X1/CLK. Input tr/tf transition edges should be about 250 ps. Use a TTC (Time transition Converter) such as Agilent 14534 (250 ps) or equivalent, if needed to slow faster edges.

Termination of a signal generator may be accomplished by placing a 50 Ω resistor (to GND) at location C42. The mounted crystal does not need to be removed for Single Ended input operation.

For Crystal operation use a fundamental Parallel Resonant crystal (see Datasheet section on “Recommended Crystal Parameters”) of 25 MHz. The board is supplied with a thru-hole 25 MHz crystal installed, but alternatively has the tabs for a surface mount crystal. The Crystal mount is

## NB3N5573DTGEVB

located on the back (underside) of the board and is permanently connected to the device inputs by traces. Crystal load caps should be mounted from each crystal pin to GND (16 74– 20 pF) to fine tune frequency.

Device frequency is selected by LVTTL/LVCMOS level inputs SEL0 and SEL1 per datasheet Table 2. Jumpers J12 (SEL0), J13 (SEL1) may be set to either VDD (HI) or GND (LO), or floated open (HI) to program the output frequency of operation. Jumpers may be removed to drive SEL0/1b directly with spec VIH or VIL levels. Note SEL0/1 inputs will default to VDD when left floating open. High Impedance probes must be used to sense the

LVTTL/LVCMOS input signal levels. Load cap may be added to fine tune frequency such as 15 pF to GND on both crystal pins.

Output current reference pin, IREF (Pin9) has a precision 475 Ω resistor (R5) installed from the output pin to GND to set the output current.

Inputs OE1 and OE2 may be jumpered to VEE (GND) for a LOW level (DISABLED) using J15 (OE1) or J12 (OE2). If floated open (jumper removed), pin will default to a HIGH level (ENABLED). High Impedance probes must be used to sense the signal levels.

### APPENDIX 1: DEVICE PIN TO BOARD CONNECTION INFORMATION (see current Datasheet)

**Table 2. DEVICE PINS TO BOARD CONNECTION**

Device Pin	Device Pin Name	Board Connection	I/O	Description
1	S0	SEL0	LVTTL/LVCMOS Input	Frequency select input 0. Internal pullup resistor to VDD. See datasheet Table 2
2	S1	SEL1	LVTTL/LVCMOS Input	Frequency select input 1. Internal pullup resistor to VDD. See datasheet Table 2
3	NC	PIN3	No Connect	No Connect
4	X1/CLK	X1/CLK	Crystal Interface	Oscillator Input from Crystal. Single ended 25 Mhz LVTTL/LVCMOS Clock Input.
5	X2	X2	Crystal Interface	Oscillator Output to drive Crystal
6	OE	OE	LVTTL/LVCMOS Input	Output Enable Input pin to control CLKx (tri-states CLKx when LOW, open pin defaults to HIGH)
7	GND	GND	Ground Supply	DUT and SMA GND Supply. All Supply pins must be connected for proper operation
8	NC	PIN3	No Connect	No Connect
9	IREF	( - )		(connects Pin 9 through 475 Ω to GND)
10	CLK1b	CLK1b	HCSL Output	HCSL Invert Output
11	CLK1	CLK1	HCSL Output	HCSL True Output
12	VDD	VDD	Positive Supply	Positive Supply pin. All Supply pins must be connected for proper operation.
13	GND	GND	Ground Supply	DUT and SMA GND Supply. All Supply pins must be connected for proper operation
14	CLK0b	CLK0b	HCSL Output	HCSL Invert Output
15	CLK0	CLK0	HCSL Output	HCSL True Output
16	GND	GND	Ground Supply	DUT and SMA GND Supply. All Supply pins must be connected for proper operation



# NB3N5573DTGEVB

## APPENDIX 3: BILL OF MATERIALS, LAMINATION STACKUP, AND ASSEMBLY NOTES

**Table 3. BILL OF MATERIAL**

Item	Qty	Schematic	Value	Size	MFG	P/N	Description
1	2	BJ1-BJ2			ITT POMONA ELECTRONICS	B-JACK 1/4-32 THREAD	BANANAJACK
2	2	C1,C2	0.1 $\mu$ F	0402	Panasonic - ECG	ECJ-DEB1A104K	CAP CERM .1UF 10% 10V X5R
3	2	C3,C4	0.01 $\mu$ F	0402	AVX Corporation	04023C103KAT2A	CAP CERM .01UF 10% 25V X7R
4	1	C9	10 $\mu$ F	7343	Kemet	T491C106K016AT	CAP TANT 10UF 16V 10% SMD
5	5	J10,J12,J13,J15,J16	2pin		Sullins Electronics Corp	PEC36SACN	CONN HEADER .100 SINGL STR 36 POS
6	5	J10,J12,J13,J15,J16			Sullins Electronics Corp	STC02SYAN	CONN JUMPER SHORTING TIN
7	4	R1,R2,R7,R8	33.2	0402	Panasonic - ECG	ERJ-2RKF33R2X	RES 33.2 $\Omega$ 1/16W 1% 0805 SMD
8	4	R3,R4,R9,R10	49.9	0402	YAGEO AMERICA	9C04021A49R8FLHF3	RES 49.9 $\Omega$ 1/16W 1% 0805 SMD
9	1	R5	475	0402	Panasonic - ECG	ERJ-2RKF49R9X	RES 475 $\Omega$ 1/16W 1% 0805 SMD
10	11	J1-6,J8,J9,J14,J17,J18			Emerson Network Power Connectivity Solutions	142-0701-801	CONN JACK END LAUNCH PCB .187" G
11	1	J11	SMT		KEystone ELECTRONICS	5016	PC TEST POINT COMPACT SMT
12	2	Y1 Socket Pins			Ampere	2-330808-8	CONN SOCKET RCPT .013-.021 30AU
13	U1				On Semiconductor	NB3N5573DT	16 lead Tssop Dut
14	4	Standoff					Nylon Standoff
15	4	Screw					Nylon Screw
16	1	Xtal			ECLIPTEK	ECX-6150-25.000M	XTAL (Do Not Solder)
17	1	SOCKET			M&M	50-000-00809	NOT INSTALLED, Not Provided

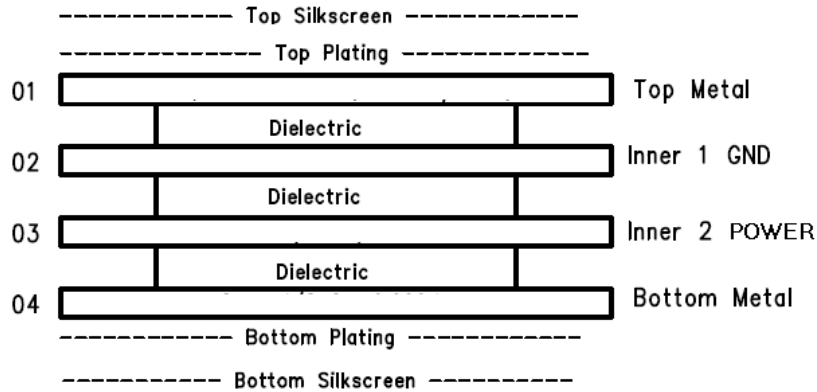

**Figure 8. Lamination Stack**

## NB3N5573DTGEVB

1. Latest revisions shall apply to all specifications.
2. Fabricate PCB in accordance with IPC-A-600; using supplied CAD Data. Board data viewed from primary side (layer 1).  
Board shall meet the requirements of UL796 with a flammability rating of 94V-0. Vendors UL logo or designation, date code, and UL rating shall be located in etch on the secondary side of the board. If space is limited, it is permissible to locate markings on secondary legend.
3. Materials: 180 TG FR4 or better, RoHS Compliant  
Refer to layer stack-up for copper weight and dielectric thickness.
4. Impedance: Refer to layer stack-up.
5. Finish - .00005" of Hard Gold over .0002" Nickel
6. Soldermask: Color - Green, Type - LPI, Sides - Bottom ONLY.
7. Legend (silkscreen): No legend allowed on exposed lands.  
Color - White, permanent, organic, non-conductive epoxy ink.
8. Electrical Test - 100% electrical test required and verified to IPC-356 netlist provided. Not applicable for double sided boards.
9. Warp and twist shall not exceed 10% (.010" per linear inch).
10. Tolerances:  
Finished Plated through hole tolerance is +/- .003".  
Non-plated through hole tolerance is +/- .001".  
Board profile +/- .010".
11. Conductor widths shall be within +/- .001 of supplied artwork (except for impedance signals).
12. Remove all burrs and sharp edges > .015".



**onsemi**, **Onsemi**, and other names, marks, and brands are registered and/or common law trademarks of Semiconductor Components Industries, LLC dba "**onsemi**" or its affiliates and/or subsidiaries in the United States and/or other countries. **onsemi** owns the rights to a number of patents, trademarks, copyrights, trade secrets, and other intellectual property. A listing of **onsemi**'s product/patent coverage may be accessed at [www.onsemi.com/site/pdf/Patent-Marking.pdf](http://www.onsemi.com/site/pdf/Patent-Marking.pdf). **onsemi** is an Equal Opportunity/Affirmative Action Employer. This literature is subject to all applicable copyright laws and is not for resale in any manner.

The evaluation board/kit (research and development board/kit) (hereinafter the "board") is not a finished product and is not available for sale to consumers. The board is only intended for research, development, demonstration and evaluation purposes and will only be used in laboratory/development areas by persons with an engineering/technical training and familiar with the risks associated with handling electrical/mechanical components, systems and subsystems. This person assumes full responsibility/liability for proper and safe handling. Any other use, resale or redistribution for any other purpose is strictly prohibited.

**THE BOARD IS PROVIDED BY ONSEMI TO YOU "AS IS" AND WITHOUT ANY REPRESENTATIONS OR WARRANTIES WHATSOEVER. WITHOUT LIMITING THE FOREGOING, ONSEMI (AND ITS LICENSORS/SUPPLIERS) HEREBY DISCLAIMS ANY AND ALL REPRESENTATIONS AND WARRANTIES IN RELATION TO THE BOARD, ANY MODIFICATIONS, OR THIS AGREEMENT, WHETHER EXPRESS, IMPLIED, STATUTORY OR OTHERWISE, INCLUDING WITHOUT LIMITATION ANY AND ALL REPRESENTATIONS AND WARRANTIES OF MERCHANTABILITY, FITNESS FOR A PARTICULAR PURPOSE, TITLE, NON-INFRINGEMENT, AND THOSE ARISING FROM A COURSE OF DEALING, TRADE USAGE, TRADE CUSTOM OR TRADE PRACTICE.**

**onsemi** reserves the right to make changes without further notice to any board.

You are responsible for determining whether the board will be suitable for your intended use or application or will achieve your intended results. Prior to using or distributing any systems that have been evaluated, designed or tested using the board, you agree to test and validate your design to confirm the functionality for your application. Any technical, applications or design information or advice, quality characterization, reliability data or other services provided by **onsemi** shall not constitute any representation or warranty by **onsemi**, and no additional obligations or liabilities shall arise from **onsemi** having provided such information or services.

**onsemi** products including the boards are not designed, intended, or authorized for use in life support systems, or any FDA Class 3 medical devices or medical devices with a similar or equivalent classification in a foreign jurisdiction, or any devices intended for implantation in the human body. You agree to indemnify, defend and hold harmless **onsemi**, its directors, officers, employees, representatives, agents, subsidiaries, affiliates, distributors, and assigns, against any and all liabilities, losses, costs, damages, judgments, and expenses, arising out of any claim, demand, investigation, lawsuit, regulatory action or cause of action arising out of or associated with any unauthorized use, even if such claim alleges that **onsemi** was negligent regarding the design or manufacture of any products and/or the board.

This evaluation board/kit does not fall within the scope of the European Union directives regarding electromagnetic compatibility, restricted substances (RoHS), recycling (WEEE), FCC, CE or UL, and may not meet the technical requirements of these or other related directives.

FCC WARNING – This evaluation board/kit is intended for use for engineering development, demonstration, or evaluation purposes only and is not considered by **onsemi** to be a finished end product fit for general consumer use. It may generate, use, or radiate radio frequency energy and has not been tested for compliance with the limits of computing devices pursuant to part 15 of FCC rules, which are designed to provide reasonable protection against radio frequency interference. Operation of this equipment may cause interference with radio communications, in which case the user shall be responsible, at its expense, to take whatever measures may be required to correct this interference.

**onsemi** does not convey any license under its patent rights nor the rights of others.

LIMITATIONS OF LIABILITY: **onsemi** shall not be liable for any special, consequential, incidental, indirect or punitive damages, including, but not limited to the costs of requalification, delay, loss of profits or goodwill, arising out of or in connection with the board, even if **onsemi** is advised of the possibility of such damages. In no event shall **onsemi**'s aggregate liability from any obligation arising out of or in connection with the board, under any theory of liability, exceed the purchase price paid for the board, if any.

The board is provided to you subject to the license and other terms per **onsemi**'s standard terms and conditions of sale. For more information and documentation, please visit [www.onsemi.com](http://www.onsemi.com).

## PUBLICATION ORDERING INFORMATION

### LITERATURE FULFILLMENT:

Email Requests to: [orderlit@onsemi.com](mailto:orderlit@onsemi.com)

**onsemi Website:** [www.onsemi.com](http://www.onsemi.com)

### TECHNICAL SUPPORT

**North American Technical Support:**

Voice Mail: 1 800-282-9855 Toll Free USA/Canada

Phone: 011 421 33 790 2910

**Europe, Middle East and Africa Technical Support:**

Phone: 00421 33 790 2910

For additional information, please contact your local Sales Representative